

Frese YDF-2F & YDF-20F - differential pressure control valve

Application

Frese YDF-2F and YDF-20F differential pressure control valves are used in central heating-, ventilation-, and district heating systems

This model is a high-performing adjustable differential pressure control valve (DPCV) installed in the supply or return piping line of loaded equipment, that ensures the differential pressure across the load or circuit is constant.



Benefits

Design

- The valve construction integrated with the Equal % Cone provides additional wide range of control of differential pressure and flow
- Being diaphragm split-system, there is no influence by temperature and being perfect balance type, solid set pressure-differential value is ensured
- Strong construction guarantees high durability.
- Being diaphragm type, installation in the horizontal and the vertical position is possible

Operation

- High comfort for the end-users due to no noise problems from control valves
- Easy adjustment of the pressure by Equal % Cone

Features

- Easy to install and adjust according to selection diagram
- Maintenance time will be referred in acc. with whether leaking water visually
- Valve lifting can be checked thru the installed indicator
- Standard sizes from DN25 to DN150
- Sizes from DN200 to DN300 on request
- Pressure class PN16 or PN25

Frese YDF-2F & YDF-20F - differential pressure control valve

Technical data

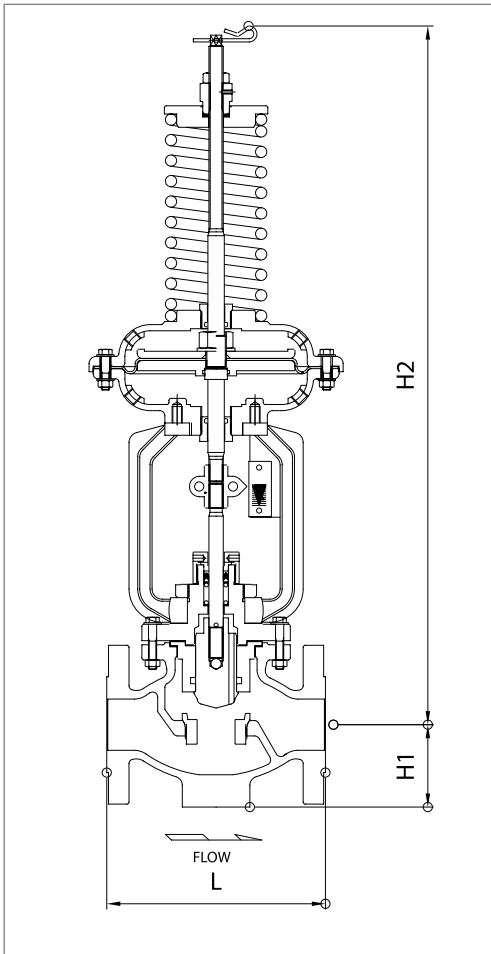

Dimension & Weight

Model	YDF-2F (PN16)			
	Size	L	H1	H2
DN25	184	62.5	640	20
DN32	180	70	650	26
DN40	222	80	658	28
DN50	254	95	670	41
DN65	276	115	720	48
DN80	298	120	720	56
DN100	352	130	735	72
DN125	400	150	775	130
DN150	451	180	800	162
DN200	543	225	1148	
DN250	730	324	1216	
DN300	850	381	1273	

Dimension & Weight

Model	YDF-20F (PN25)			
	Size	L	H1	H2
DN25	197	62.5	640	21
DN32	180	70	650	26
DN40	235	80	658	30
DN50	267	95	670	43
DN65	292	115	720	54
DN80	318	120	720	65
DN100	368	130	735	83
DN125	400	150	775	152
DN150	473	180	800	203
DN200	568	225	1148	
DN250	740	324	1216	
DN300	850	381	1273	

Frese YDF-2F & YDF-20F - differential pressure control valve

Specifications

Items	YDF-2F	YDF-20F
Pressure class	PN16	PN25
Applicable fluid	Hot & cold water	
Flow temperature	Max 170°C	
Construction	Diaphragm	
Differential pressure adjustment range (kPa)	20 - 200 kPa or 150-500 kPa	
Flange connection	EN 1092-2 PN16	EN 1092-2 PN25
Materials	Body	Cast Iron
	Diaphragm	Cast Steel
Connection parts, 2 sets	EPDM	
	Capillary copper tube $\varnothing 6.35 \times 0.9$ L= 2m	
	Manometer 1/4" connection	
	Ball valve 1/4"	
	Tee 1/4"	
	Nipple 1/4"	
	Extension pipe 1/4"	

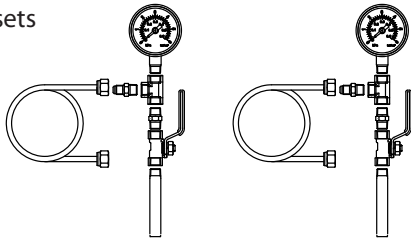

Product program

Size	Control range [kPa]	YDF-2F PN16	YDF-20F PN25
DN25	20 - 200	53-3060	53-3090
	150 - 500	53-3075	53-3105
DN32	20 - 200	53-3061	53-3091
	150 - 500	53-3076	53-3106
DN40	20 - 200	53-3062	53-3092
	150 - 500	53-3077	53-3107
DN50	20 - 200	53-3063	53-3093
	150 - 500	53-3078	53-3108
DN65	20 - 200	53-3064	53-3094
	150 - 500	53-3079	53-3109
DN80	20 - 200	53-3065	53-3095
	150 - 500	53-3080	53-3110
DN100	20 - 200	53-3066	53-3096
	150 - 500	53-3081	53-3111
DN125	20 - 200	53-3067	53-3097
	150 - 500	53-3082	53-3112
DN150	20 - 200	53-3068	53-3098
	150 - 500	53-3083	53-3113
DN200	20 - 200	53-3069	53-3099
	150 - 500	53-3084	53-3114
DN250	20 - 200	53-3070	53-3100
	150 - 500	53-3085	53-3115
DN300	20 - 200	53-3071	53-3101
	150 - 500	53-3086	53-3116

Frese YDF-2F & YDF-20F - differential pressure control valve

Construction Drawing

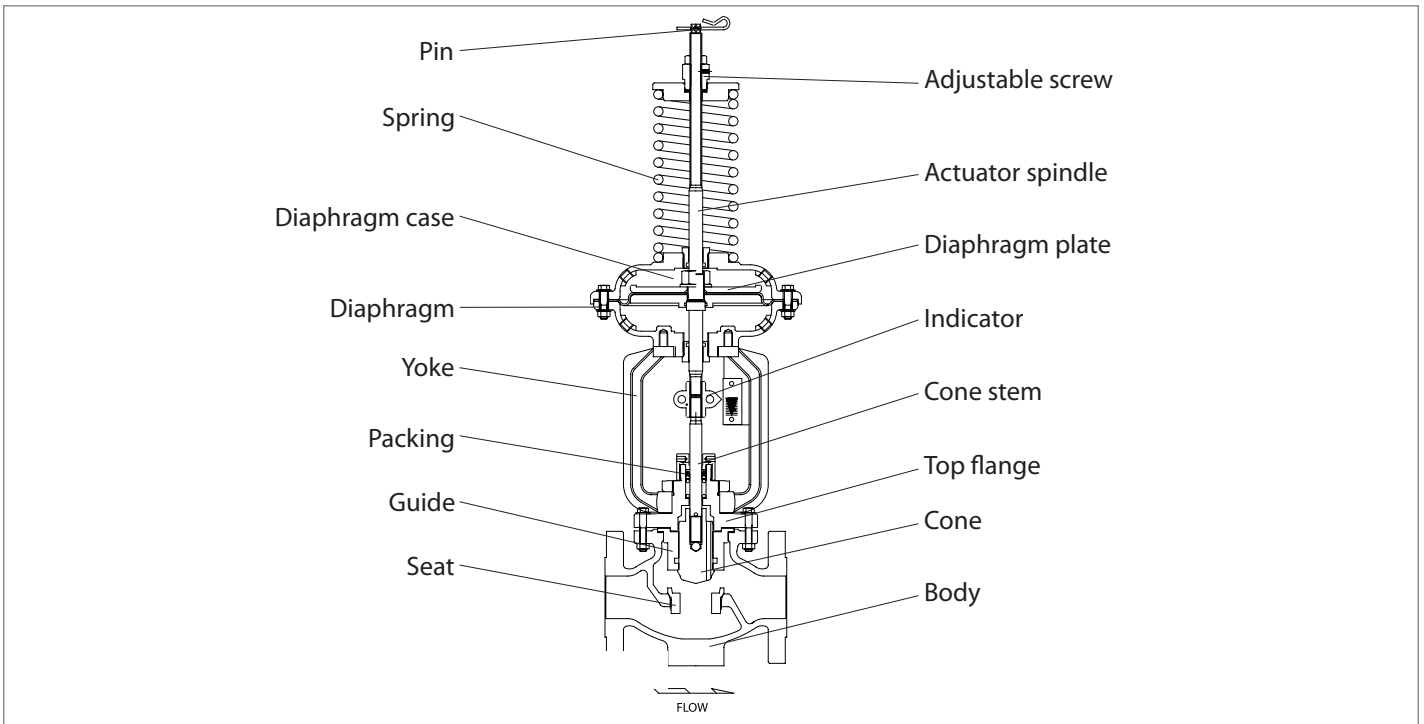

Selection of valve size

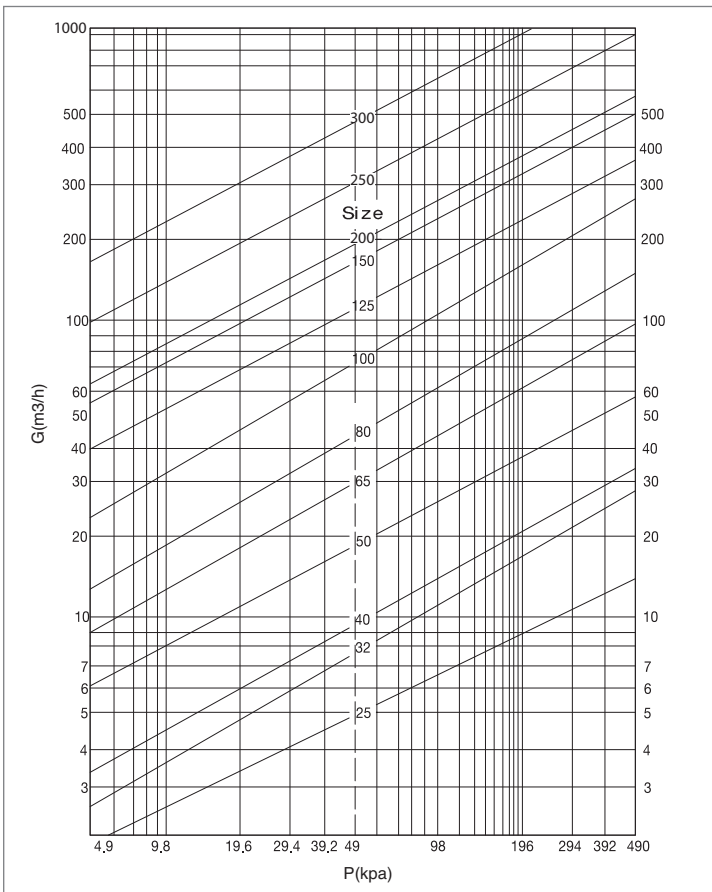

$$Cv = \frac{1.167 \times Q \times \sqrt{r}}{\sqrt{\Delta P}}$$

Cv: Coeffience of valve

Q: Flow (m³/h)

r: Density (water = 1)

ΔP: Differential pressure across valve (Bar)

Size	Cv
DN25	8
DN32	12.5
DN40	18
DN50	32
DN65	50
DN80	72
DN100	128
DN125	200
DN150	288
DN200	320
DN250	510
DN300	800

Frese YDF-2F & YDF-20F - differential pressure control valve

How to adjust differential pressure

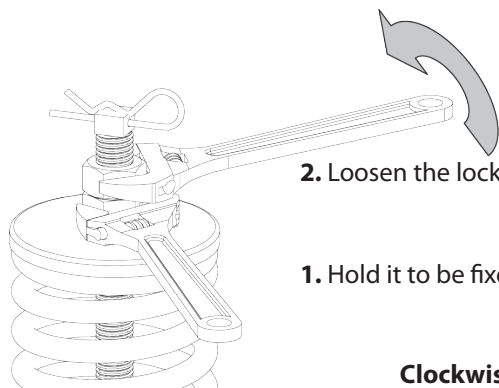

2. Loosen the lock nut along the direction of arrow indicated

1. Hold it to be fixed until the lock nut is loosened

Clockwise:
increase of differential pressure

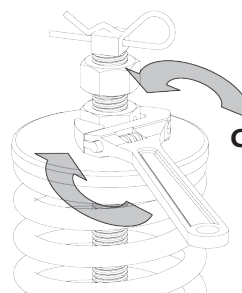

Counterclockwise:
ease of differential pressure

How to adjust differential pressure

Make sure to fully comprehend the following cautions in handling the products so that the product may display its performance.

1. Do not apply any impact on it
2. Avoid any place with dust or humidity when storing it
3. A special attention should be paid so that any impurities are not inserted into the product
4. When attaching it onto a pipe, the location should be free of sand or debris while a point of gasket should be also cleaned up
5. It should be installed on a place easy to access for repair

*The structure, dimensions and materials may be changed without any prior notice for the improvement of performance.

Maintenance tips

Stuffing nut box packing leaking

1. Locking after checking gate valve - Main valve locking
2. Pressure pipe valve locking
3. Slowly loosening after checking the height of the spring specified
4. Separating the pressure pipe
5. Loosening after checking the height of indicator \varnothing s stamp thread
6. Slowly loosening Stuffing nut box
- Stop disassembly if water continuously flows
7. Checking and replacing the packing and reversely assembling it

O-ring leaking

1. Checking and locking gate valve
2. Pressure pipe valve locking
3. Checking and slowly loosening the height of spring specified
4. Separating the pressure pipe
5. Loosening after checking the height of stamp thread
6. Disassembling the actuator
7. If it's rusty excessively, it should be ground with soft sand paper
8. Replace O-ring and assembling it

Frese A/S assumes no responsibility for errors, if any, in catalogues, brochures, and other printed matter. Frese A/S reserves the right to modify its products without prior notice, including already ordered products, if this does not alter existing specifications. All registered trademarks in this material are the property of Frese A/S. All rights reserved.

Frese A/S
Sorøvej 8
DK- 4200 Slagelse
Tel: +45 58 56 00 00
Fax: +45 58 56 00 91
info@frese.dk